

S.NO	CATALOG NUMBER	D	W	H
1	BASE153030SP	15 [381]	30 [762]	30 [762]
2	BASE183030SP	18 [457]	30 [762]	30 [762]
3	BASE186030TP	18 [457]	60 [1524]	60 [1524]
4	BASE223030SP	22 [559]	30 [762]	30 [762]
5	BASE226630TP	22 [559]	66 [1676]	30 [762]

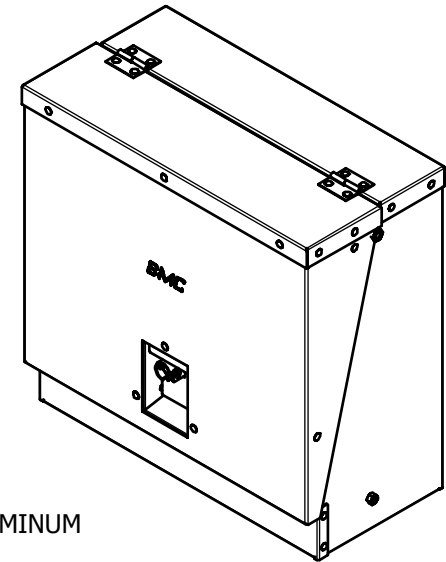
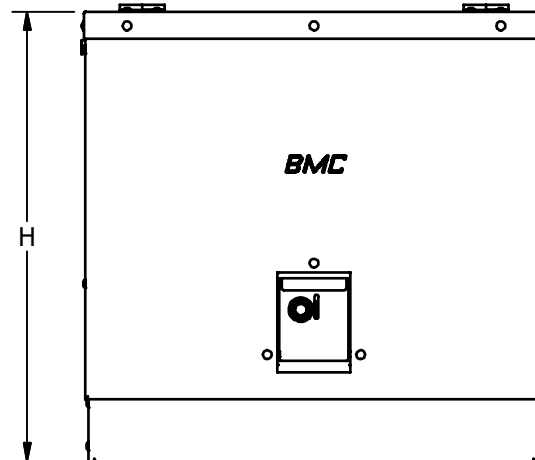
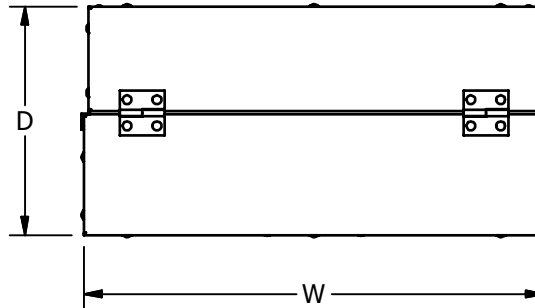

NOTES:

1. MATERIAL: ALUMINUM
2. SINGLE OR THREE PHASE.
3. STAINLESS STEEL PENTA-HEAD BOLT AND STAINLESS STEEL PADLOCKING HANDLE.
4. ALL STAINLESS STEEL HARDWARE.
5. GROUND LUGS LOCATED ON MOUNTING PLATE AND ON THE ENCLOSURE FOR CONCENTRIC NEUTRAL.
6. MOUNTING PLATES ARE AVAILABLE TO FIT 2, 3, OR 4 WAY MULTI-TAPS WITH PARKING STAND.
7. ALUMINUM, STEEL OR FIBERGLASS BURIAL SLEEVES AVAILABLE.
8. A WIND STOP IS INCLUDED ON ALL TOP HINGED UNITS FOR OPERATING SAFETY.
9. DESIGNED TO MEET ANSI C57.12.28-1988

					TO ORDER CMC PRODUCTS	DRAWN BY: TS	NAME OF PART:	CAT. NO.:
					UNITED STATES 1-513-860-4455	04-07-20	PRIMARY SECTIONALIZING ENCLOSURES	SEE TABLE
					CANADA 1-800-361-6975	CHECKED BY:	DWG NO:	A
					MEXICO 011-52-722-265-4400		UB22700253-S (CHARTED)	
A	NEW DRAWING CREATED		04-07-20	TS	FOR PRODUCT INFO www.cmlugs.com	DRAWING NOT TO SCALE		SHEET NO: 1 OF 1
REV.	DESCRIPTION	ECN	DATE	INIT.				

THIS INFORMATION IS PROPRIETARY TO CONNECTOR MFG. CO. AND IS NOT TO BE DISCLOSED OUTSIDE OF CONNECTOR MFG. CO. WITHOUT A CONFIDENTIALITY AGREEMENT



CONNECTOR MANUFACTURING CO.

HAMILTON, OHIO

